

CENT1120

Universal 120 Watt Series



- 100-240 VAC Universal Input
- Desktop Style
- Complies with EMI/RFI Regulations
- CE Compliant (LVD, EMC, WEEE, RoHS)
- Impact Resistant, Non-vented Polycarbonate Enclosure
- IPX1 Compliant
- Modified and Custom Designs also Available
- Meets ENERGY STAR Criteria Level IV and EISA Requirements — see page three for details



International Safety Standard Approvals



Specifications

Output Specifications

Line Voltage Regulation	Including Cord	2%
Load Voltage Regulation	Including Cord	5%
Ripple		1% Vp-p of Vnorm, max.
Transient Response		5 msec from 25% to 75% load change typ., <+/-5% Over/Undershoot
Turn on Delay		Less than 3s over entire input range
Turn on Overshoot		Less than +/-5% of Vnorm. over entire input range
Over Temperature Protection		Active
Over Current Protection		Higher than 120% of Inorm. Cyclic Mode
Short Circuit Protection		Cyclic Mode
Temp. Coefficient		±0.05% / °C
Protection Mode		Auto Recovery OCP, SCP Latch protection OTP ,OVP

Input Specifications

Voltage		100-240VAC -10%, +10%
Line Frequency		47-63Hz
Input Current		2.0A max. @ 90VAC
Protection		Internal primary current fuse
Power Factor Correction		Complies with EN61000-3-2 class D

Environmental Specifications

Thermal Performance	Operating Temperature	0° C to 40° C with no Derating
Cooling	Convectional	Non-ventilated Enclosure
Relative Humidity	Non-condensing	5% to 95%
Altitude		0-10,000 feet
Storage Temp		-20° C to +85° C

CENT1120

Universal 120 Watt Series

For the most current data and application support visit www.sipower.com

Ault Part Number	Output Voltage	Output Currents		Max Watts	Max OVP
		Min	Max		
CENT1120A1251F01	12 V	0.00 A	9.17 A	110.0 W*	20 V
CENT1120A1551F01	15 V	0.00 A	7.33 A	110.0 W	25 V
CENT1120A1851F01	18 V	0.00 A	6.67 A	120.0 W	27 V
CENT1120A2451F01	24 V	0.00 A	5.00 A	120.0 W	36 V
CENT1120A4803F01	48 V	0.00 A	2.50 A	120.0 W	72 V

*12V model rated 100W with input voltages rated 100-110VAC, 110W with input voltages rated 110VAC-240VAC

General Specifications		
Topology	Two stage conversion and Quasi-resonate Flyback	
Dielectric Withstand	Primary-Secondary Primary-Ground Secondary-Ground	3000VAC, 4242VDC 1500VAC, 2121VDC 500VDC
Spacing	Primary-Secondary	8mm min.
Leakage Current 1	Primary side to Earth < 3.5 mA in Normal State	
Leakage Current 2	Output- to Earth < 0.25mA in Normal State	
Efficiency	(excluding cord)	88% Typical
MTBF	100,000 Calculated Hours	
Hold-up Time	16.7 msec typ. @ 110VAC 30 msec typ. @ 220VAC	
Certifications	UL, EN (TUV), EN60601-1	
Weight	(excluding cord)	24 oz (684 g)
Case and Dimension	6.6L X 3.2W X 1.6H (in) 167L X 82W X 40H (mm)	
Case Material	Black 94V0 Polycarbonate	
Cord and Connector	1.0m long for 12V 1.8m long for 15V/18V/24V/48V, 18AWG cable with AULT #51 connector. For 12V/15V/18V/24V, 18AWG cable with AULT #3 plug for 48V	
EMI/EMC Information	Conducted Emissions EN55022 Class B Radiated Emissions EN55022, FCC Part15 Class B Line freq. Harmonics EN61000-3-2 Class D Voltage Fluctuations EN61000-3-3 Complies ESD EN61000-4-2 Cont. 6kV, air 8KV Radiated Immunity EN61000-4-3 3V/m Fast Transients (EFT) EN61000-4-4 2KV 5KHz Line Surge Immunity EN61000-4-5 2KV CM, 1KV Diff. Conducted Immunity EN61000-4-6 3Vrms Power Freq. Mag. Field EN61000-4-8, 3A/m Perf Criteria A Voltage Dip Immunity EN61000-4-11, 70% UT for 10mS, 40% UT for 100mS, <5% UT for 5000mS, Perf Criteria A, B, B	

Ault Part Number Key

C	E	N	T	1	120
Commercial	External	Input Range	Factory Location	No. of Outputs	Output Wattage

Input Connectors



IEC320
w/ground
C14
(F)

Optional Features

Private label marking

Output Connectors

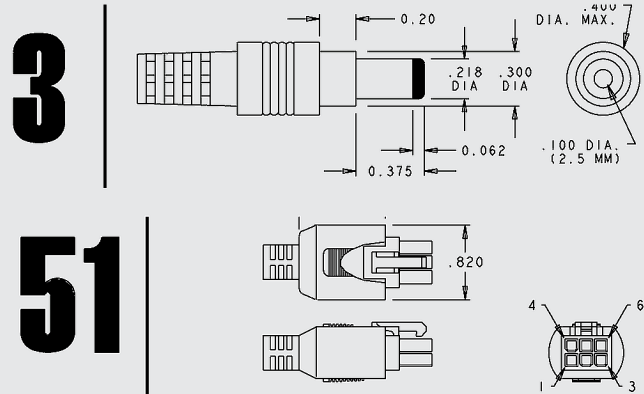

CENT1120

Universal 120 Watt Series

For the most current data and application support visit www.sipower.com

2007 Energy Independence and Security Act – EISA

The Energy Independence and Security Act of 2007 was passed in December of 2007 and addresses minimum efficiency standards and standby levels for Class A external power supplies that are 250 watts and under. This law stipulates that external power supplies manufactured on July 1, 2008 and beyond meet certain minimum efficiency and standby criteria as defined below.

Minimum Efficiency Criteria

Active mode is defined as when a power supply's input is connected to line voltage AC and its output is connected to a DC or AC load drawing a portion of the product's power output. Depending on the power rating for the power supply, it must meet the minimum efficiency criteria outlined below.

Energy-Efficiency Criteria for Active Mode:

output power on adapter label	minimum average efficiency percentage
0 to \leq less than 1 watt	$\geq 0.50 * \text{output power on adapter label}$
> 1 to \leq 51 watts	$\geq [0.09 * \text{Ln (output power on adapter label)}] + 0.50$
> 51 watts	≥ 0.85

The power supply must also meet a requirement for when its input is connected to a line voltage AC but its output is not connected to a load. Depending on the power output of the supply, it must keep its energy consumption below the following values.

Energy Consumption Criteria for No Load Mode:

output power on adapter label	maximum power consumption in no-load mode
0 to < 250 watts	≤ 0.5 watts